

MADE IN ITALY



# Chambord

60x120 - 60x90 - 30x90 - 60x60 - 20x60



GRES PORCELLANATO  
PORCELAIN . GRÈS CÉRAMÉ . FEINSTEINZEUG





*Gres porcellanato*  
PORCELAIN . GRÉS CÉRAME . FEINSTEINZEUG

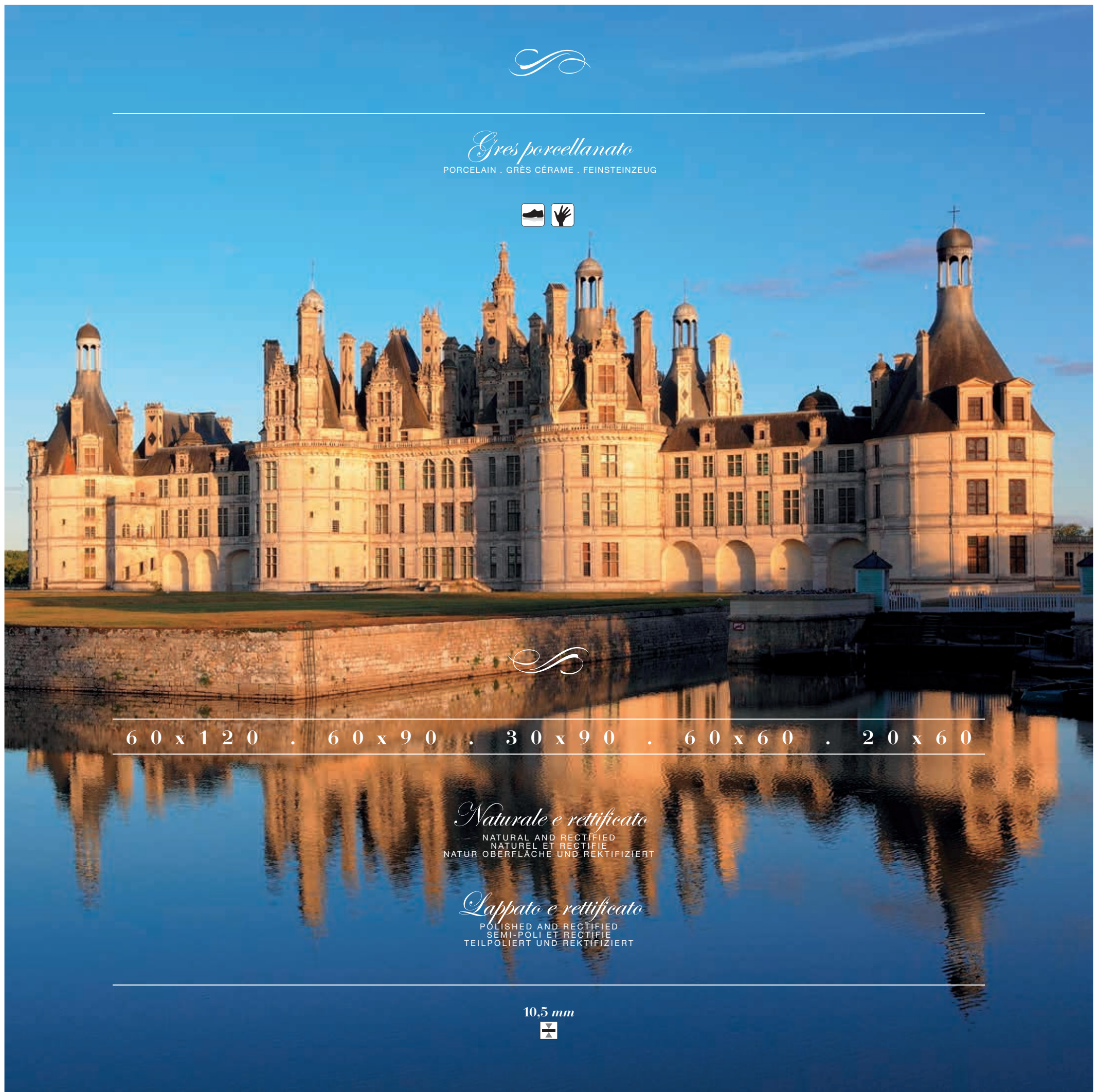

60 x 120 . 60 x 90 . 30 x 90 . 60 x 60 . 20 x 60

*Naturale e rettificato*  
NATURAL AND RECTIFIED  
NATUREL ET RECTIFIÉ  
NATUR OBERFLÄCHE UND REKTIFIZIERT

*Lappato e rettificato*  
POLISHED AND RECTIFIED  
SEMI-POLI ET RECTIFIÉ  
TEILPOLIERT UND REKTIFIZIERT

10,5 mm



# Chambord



## CERAMICHE ITALIANE PER CASE DA RE.

ITALIAN CERAMIC TILES FIT FOR A KING'S CASTLE.  
DES CÉRAMIQUES ITALIENNES POUR DES MAISONS DE ROI.  
ITALIENISCHE KERAMIKEN FÜR KÖNIGLICHE HEIME.





**GRANDE** nella forma,  
*prezioso* nella sostanza.

Grand in size, precious in substance.

Grand au niveau de la forme, précieux au niveau de la substance.

Großartig in der Form, wertvoll in der Substanz.

**60x120**

60x90 - 30x90 - 60x60 - 20x60



# Chambord

*Gres porcellanato*

PORCELAIN . GRÈS CÉRAME . FEINSTEINZEUG

Quando la tradizione incontra la modernità. Chambord rende omaggio al fascino antico e grandioso dei castelli della Loira con una collezione in gres porcellanato a effetto pietra, dedicata agli ambienti del vivere contemporaneo.

Cinque formati, tre colori e due finiture superficiali per rispondere a diverse esigenze progettuali di interni ed esterni per creare atmosfere dalla rinnovata eleganza.

Tradition meets modernity.

Chambord celebrates the charm and magnificence of the Loire valley castles with a stone effect porcelain stoneware collection, dedicated to contemporary living environments.

Five sizes, three colours and two surface finishes meet the different interior and exterior design requirements creating atmospheres of renewed elegance.

Quand la tradition rencontre la modernité.

Chambord rend hommage au charme ancien et grandiose des châteaux de la Loire avec une collection en grès cérame avec effet pierre, dédiée aux espaces de la vie contemporaine.

Cinq formats, trois couleurs et deux finitions de surface pour répondre à différentes exigences de conception d'espaces intérieurs et extérieurs afin de créer des atmosphères d'une élégance renouvelée.

Wenn die Tradition auf die Modernität trifft.

Chambord würdigt die antike und grandiose Faszination der Schlösser an der Loire, über eine Kollektion aus Feinsteinzeug mit Steineffekt, die für Räumen des zeitgenössischen Lebens vorgesehenen ist.

Fünf Formate, drei Farben und zwei Oberflächenausführungen, um den unterschiedlichen Planungsanforderungen für innen und außen gerecht zu werden und Atmosphären mit erneuerter Eleganz zu schaffen.

**richenia**  
ECCCELLENZA CERAMICA ITALIANA

*Lappato e rettificato*

POLISHED AND RECTIFIED  
SEMI-POLI ET RECTIFIÉ  
TEILPOLIERT UND REKTIFIZIERT

*Naturale e rettificato*

NATURAL AND RECTIFIED  
NATUREL ET RECTIFIÉ  
NATUR OBERFLÄCHE UND REKTIFIZIERT



Chambord Bianco/Grigio

30x90 - 60,5x91 R11



Rivestimento . Wall tile:  
Bianco Modulo rete 30x30

Pavimento . Floor:  
INDOOR - Bianco 30x90  
OUTDOOR - Grigio 60,5x91 R11



Chambord

*Outdoor*

*Gres porcellanato*

PORCELAIN . GRÉS CÉRAMÉ . FEINSTEINZEUG



**60,5x91**

**R11**

**A+B**

Totale resistenza e sicurezza per gli esterni con la **superficie antiscivolo R11 A+B** nel formato 60,5x91 nei colori Grigio e Beige. Per completare ogni tuo spazio con coerenza ed eleganza.

Total resistance and safety outdoors with the **R11 A+B non-slip surface** in the 60,5x91 size, available in Grey and Beige. Solutions to complete every space with coherence and elegance.

Résistance et sécurité totales pour les espaces extérieurs avec la **surface antidérapante R11 A+B** dans le format 60,5x91 et dans les coloris Gris et Beige. Pour compléter chacun de vos espaces avec cohérence et élégance.

Totale Beständigkeit und Sicherheit für außen mit rutschsicheren **R11 A+B-zertifizierten Flächen** im Format 60,5x91 und den Farben Grau und Beige. Damit Sie alle Ihre Räume mit Schlüssigkeit und Eleganz fertigstellen können.



*Naturale*

NATURAL  
NATUREL  
NATUR OBERFLÄCHE

10,5 mm





## Chambord Bianco

60x120 - 60x90 - 60x60





# Chambord Bianco

60 x 120



Pavimento . Floor:  
Bianco 60x120  
Tabacco Inserto in legno 15x120 (NTU R113)

Rivestimento . Wall tile:  
Pavé di Sichenia: Collection "Pavé Wall" - Bianco (1650)



Chambord Beige  
60x120 - 60x90 - 60x60





# Chambord Beige

60 x 120

Rivestimento . Wall tile:

Beige 60x120 . Modulo rete 30x30

Pavimento . Floor:

Sichenia: Collection "Nature"

Tabacco 20x120 . 15x120 . Gradino Costa Retta 33x120





## Chambord Grigio

60x120 . 60x90 . 60x60 naturale





# Chambord

## BIANCO

GRES PORCELLANATO  
PORCELAIN . GRÉS CÉRAMÉ . FEINSTEINZEUG



10,5 mm:  
60x120  
60x90 - 30x90  
60x60 - 20x60

NATURALE .  
NATURAL .  
NATUREL .  
NATUR.  
60,5x91 - 60,5x60,5  
24"x36" 24"x24"

NATURALE E RETTIFICATO .  
NATURAL AND RECTIFIED .  
NATUREL ET RECTIFIÉ .  
NATUR OBERFLÄCHE UND REKTIFIZIERT .  
60x120 - 60x90 - 30x90 - 60x60 - 20x60  
24"x48" 24"x36" 12"x24" 24"x24" 8"x24"

LAPPATO E RETTIFICATO .  
POLISHED AND RECTIFIED .  
SEMI-POLIÉ ET RECTIFIÉ .  
TEILPOLIERT UND REKTIFIZIERT .  
60x120 - 60x90 - 30x90 - 60x60 - 20x60  
24"x48" 24"x36" 12"x24" 24"x24" 8"x24"



4

2 **CHB C561** - Terminale 4x60 Lappato

Pz. Box 15 **77**

**7593** - Listello Alluminio 0,8x60

Pz. Box 6 **26**

**LAC61S** - Listello Acciaio Swarosky 1,5x61

Pz. Box 3 **35**

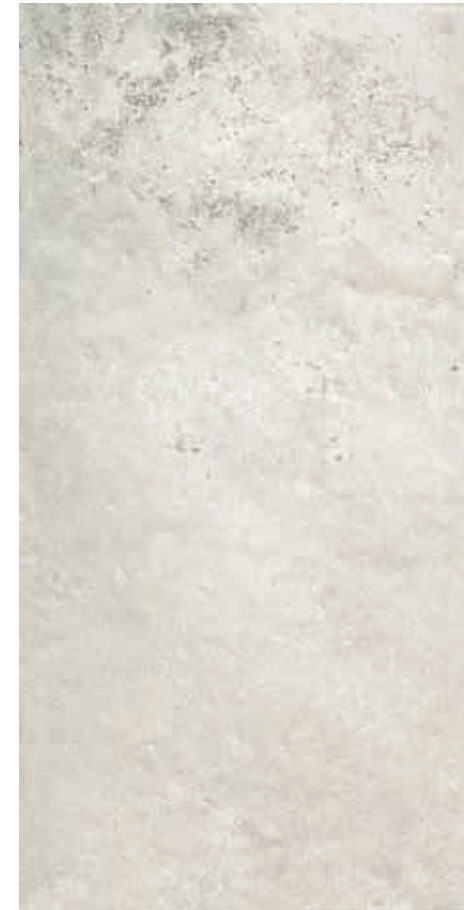

**CHB R611** - 60x120 Naturale Rettificato

R9 **62**

**CHB P611** - 60x120 Lappato Rettificato

**65**



**CHB R261** - 20x60 Naturale Rettificato

R9 **60**

**CHB P261** - 20x60 Lappato Rettificato

**63**

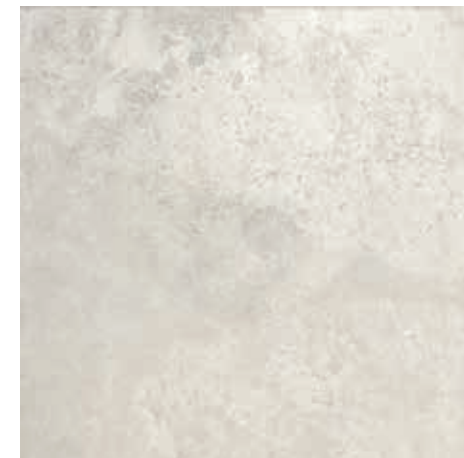

**CHB O601** - 60,5x60,5 Naturale

R9 **53**

**CHB R601** - 60x60 Naturale Rettificato

R9 **58**

**CHB P601** - 60x60 Lappato Rettificato

**62**

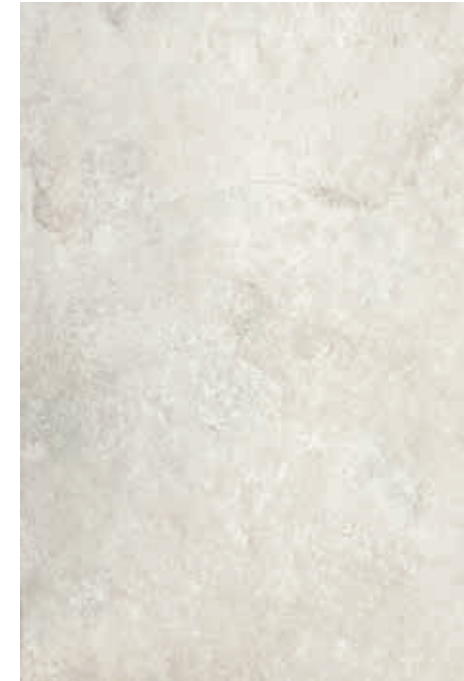

**CHB O691** - 60,5x91 Naturale

R9 **56**

**CHB R691** - 60x90 Naturale Rettificato

R9 **60**

**CHB P691** - 60x90 Lappato Rettificato

**64**



**CHB R391** - 30x90 Naturale Rettificato

R9 **62**

**CHB P391** - 30x90 Lappato Rettificato

**65**

# Chambord

## BEIGE

GRES PORCELLANATO  
PORCELAIN . GRÉS CÉRAMÉ . FEINSTEINZEUG



10,5 mm:  
60x120  
60x90 - 30x90  
60x60 - 20x60

NATURALE .  
NATURAL .  
NATUREL .  
NATUR.  
60,5x91 - 60,5x60,5  
24"x36" 24"x24"

NATURALE E RETTIFICATO .  
NATURAL AND RECTIFIED .  
NATUREL ET RECTIFIÉ .  
NATUR OBERFLÄCHE UND REKTIFIZIERT .  
60x120 - 60x90 - 30x90 - 60x60 - 20x60  
24"x48" 24"x36" 12"x24" 24"x24" 8"x24"

LAPPATO E RETTIFICATO .  
POLISHED AND RECTIFIED .  
SEMI-POLIÉ ET RECTIFIÉ .  
TEILPOLIERT UND REKTIFIZIERT .  
60x120 - 60x90 - 30x90 - 60x60 - 20x60  
24"x48" 24"x36" 12"x24" 24"x24" 8"x24"



4

2 **CHB C562** - Terminale 4x60 Lappato

Pz. Box 15 **77**

**7593** - Listello Alluminio 0,8x60

Pz. Box 6 **26**

**LAC61S** - Listello Acciaio Swarosky 1,5x61

Pz. Box 3 **35**

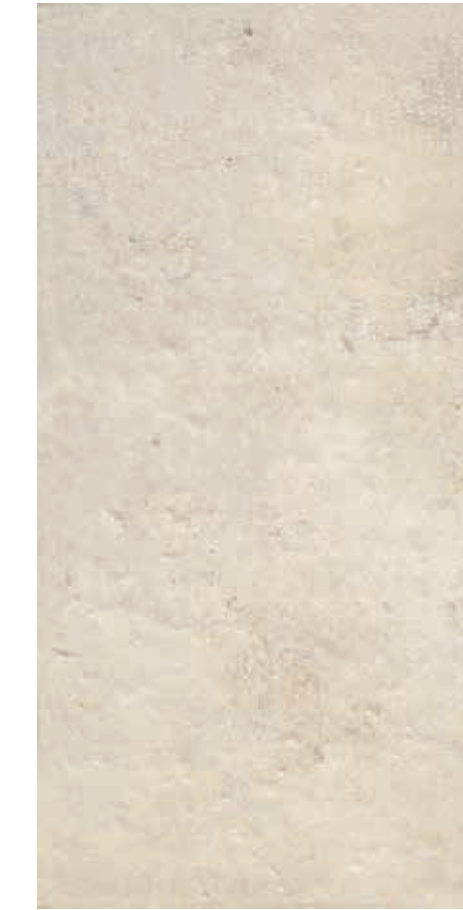

**CHB R612** - 60x120 Naturale Rettificato

R9 **62**

**CHB P612** - 60x120 Lappato Rettificato

**65**



**CHB R262** - 20x60 Naturale Rettificato

R9 **60**

**CHB P262** - 20x60 Lappato Rettificato

**63**



**CHB O602** - 60,5x60,5 Naturale

R9 **53**

**CHB R602** - 60x60 Naturale Rettificato

R9 **58**

**CHB P602** - 60x60 Lappato Rettificato

**62**



**CHB O692** - 60,5x91 Naturale

R9 **56**

**CHB R692** - 60x90 Naturale Rettificato

R9 **60**

**CHB P692** - 60x90 Lappato Rettificato

**64**



**CHB R392** - 30x90 Naturale Rettificato

R9 **62**

**CHB P392** - 30x90 Lappato Rettificato

**65**

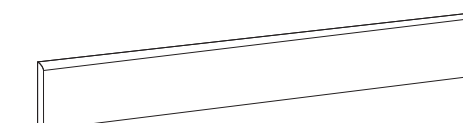
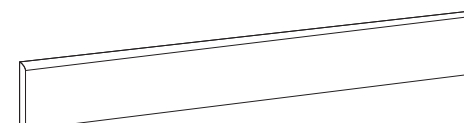



# Chambord

GRES PORCELLANATO  
PORCELAIN . GRÉS CÉRAMÉ . FEINSTEINZEUG



10,5 mm:  
60x120  
60x90 - 30x90  
60x60 - 20x60

NATURALE .  
NATURAL .  
NATUREL .  
NATUR.  
60,5x91 - 60,5x60,5  
24"x36" 24"x24"

NATURALE E RETTIFICATO .  
NATURAL AND RECTIFIED .  
NATUREL ET RECTIFIÉ .  
NATUR OBERFLÄCHE UND REKTIFIZIERT .  
60x120 - 60x90 - 30x90 - 60x60 - 20x60  
24"x48" 24"x36" 12"x24" 24"x24" 8"x24"

LAPPATO E RETTIFICATO .  
POLISHED AND RECTIFIED .  
SEMI-POLIÉ ET RECTIFIÉ .  
TEILPOLIERT UND REKTIFIZIERT .  
60x120 - 60x90 - 30x90 - 60x60 - 20x60  
24"x48" 24"x36" 12"x24" 24"x24" 8"x24"



PEZZI SPECIALI  
Special pieces . Pièces spéciales . Spezialteile

# GRIGIO



**CHB R613** - 60x120 Naturale Rettificato **R9** 62  
**CHB P613** - 60x120 Lappato Rettificato 65

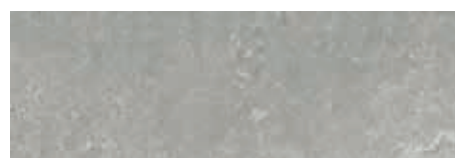

**CHB R263** - 20x60 Naturale Rettificato **R9** 60  
**CHB P263** - 20x60 Lappato Rettificato 63



**CHB C563** - Terminale 4x60 Lappato  
Pz. Box 15 77

**7593** - Listello Alluminio 0,8x60  
Pz. Box 26

**LAC61S** - Listello Acciaio Swarosky 1,5x61  
Pz. Box 35



**CHB O693** - 60,5x91 Naturale **R9** 56  
**CHB R693** - 60x90 Naturale Rettificato **R9** 60  
**CHB P693** - 60x90 Lappato Rettificato 64



**CHB O603** - 60,5x60,5 Naturale **R9** 53  
**CHB R603** - 60x60 Naturale Rettificato **R9** 58  
**CHB P603** - 60x60 Lappato Rettificato 62

Battiscopa Naturale 7x60,5 22 Battiscopa Lappato 7x60 25  
**CHB B763** - Grigio **CHB BP63** - Grigio

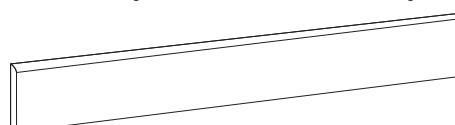

# Chambord i moduli rete

GRES PORCELLANATO  
PORCELAIN . GRÉS CÉRAMÉ . FEINSTEINZEUG



## BIANCO

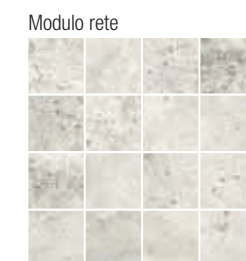

Modulo rete  
**CHB M321** - 30x30 - 12"x12"  
Naturale (7,5x7,5 - 3"x3")  
Pz. Box 24



Modulo rete  
**CHB M311** - 30x30 - 12"x12"  
Lappato (4x4 - 1"1/2x1"1/2)  
Pz. Box 27

## BEIGE

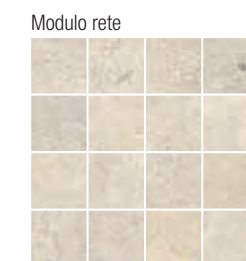

Modulo rete  
**CHB M322** - 30x30 - 12"x12"  
Naturale (7,5x7,5 - 3"x3")  
Pz. Box 24



Modulo rete  
**CHB M312** - 30x30 - 12"x12"  
Lappato (4x4 - 1"1/2x1"1/2)  
Pz. Box 27

## GRIGIO

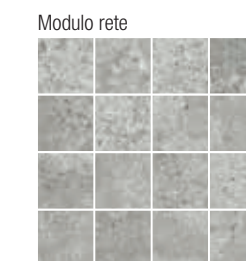

Modulo rete  
**CHB M323** - 30x30 - 12"x12"  
Naturale (7,5x7,5 - 3"x3")  
Pz. Box 24

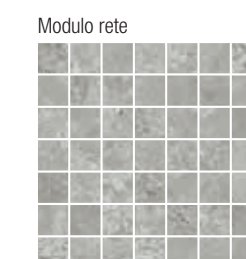

Modulo rete  
**CHB M313** - 30x30 - 12"x12"  
Lappato (4x4 - 1"1/2x1"1/2)  
Pz. Box 27

### I SUGGERIMENTI DEI NOSTRI ARCHITETTI

Our architects' suggestions.  
Les suggestions de nos architectes.  
Vorschläge unserer Architekten.

## Decorare gli ambienti con i moduli rete

Decorating spaces with the netting-backed modules.  
Décorer les espaces avec les modules rete (filet).  
Die Räume mit den Netzmodulen dekorieren.

Può essere utilizzato per rivestire interamente una parete, ma anche come fascia per decorare e arricchire le composizioni. Adatto anche a pavimento per disegnare tappeti e pedane.

On peut l'utiliser pour revêtir entièrement un mur, mais aussi comme une bande pour décorer et enrichir les compositions. Egalement indiqué au sol pour dessiner des tapis et des marche-pieds.

This module can be used to cover a whole wall or as decorative strip to enrich the design solutions. It is also suitable to define carpet and mat-like decorations.

Kann zum Verkleiden einer ganzen Wand, aber auch als Streifen zum Dekorieren und Ausschmücken von Zusammenstellungen benutzt werden. Eignet sich auch als Boden zur Schaffung von Teppichen und Podesten.

Con il **modulo rete 30x30** è possibile ricavare fasce di mosaico più o meno alte in base alle esigenze di stile dell'ambiente. Si ottengono eleganti risultati sia utilizzando lo stesso colore del fondo che colori diversi a contrasto.

Le **modulo rete (filet) 30x30** permet de réaliser des frises en mosaïques plus ou moins hautes en fonction des exigences stylistiques de la pièce. On obtient des résultats élégants en utilisant la même couleur de fond ou des couleurs différentes et contrastantes.

The **30x30 rete module** is suitable to create strips of mosaic of different heights according to the style of the space. Elegant solutions can be created by using the same basic colour or contrasting colours.

Mit dem **Netzmodul 30x30** können je nach den Raumanforderungen mehr oder wenig hohe Mosaikstreifen geschaffen werden. Man erzielt elegante Ergebnisse sowohl bei Verwendung der selben Untergrundfarbe als auch mit unterschiedlichen Farben als Kontrast.

TESSERA . TESSERAE . TESSELLE . MUSTER

7,5x7,5 - 3"x3"

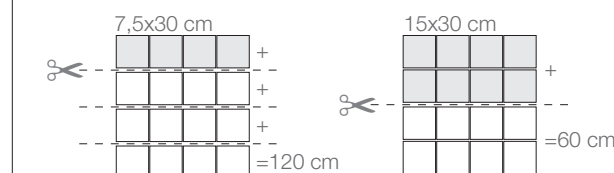

TESSERA . TESSERAE . TESSELLE . MUSTER

4x4 - 1"1/2x1"1/2

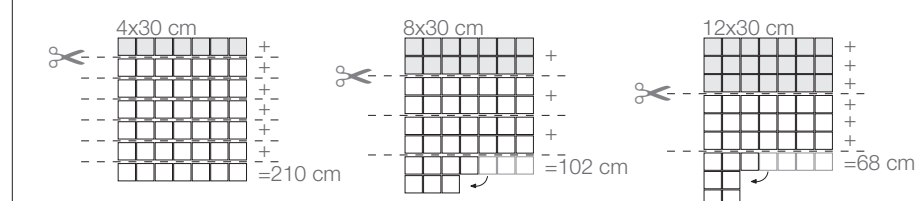



# Chambord i gradini

GRES PORCELLANATO  
PORCELAIN . GRÈS CÉRAMÉ . FEINSTEINZEUG



Gradino Costa Retta  
33x120 Naturale (80)

**CHB G311** - Bianco  
**CHB G312** - Beige  
**CHB G313** - Grigio

Gradino Costa Retta  
33x120 Lappato (81)

**CHB G321** - Bianco  
**CHB G322** - Beige  
**CHB G323** - Grigio

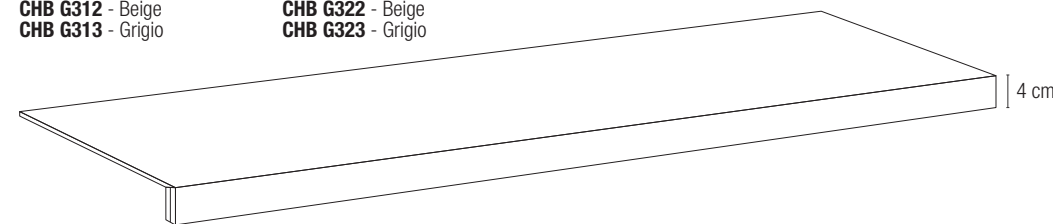

Angolo Gradino Costa Retta SX  
33x120 Naturale (82)

**CHB A331** - Bianco  
**CHB A332** - Beige  
**CHB A333** - Grigio

Angolo Gradino Costa Retta SX  
33x120 Lappato (83)

**CHB A341** - Bianco  
**CHB A342** - Beige  
**CHB A343** - Grigio

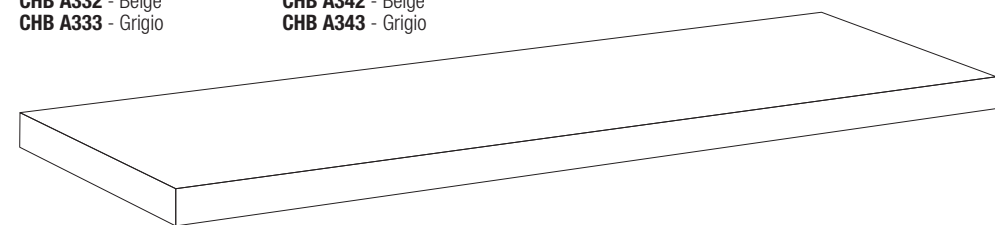

Angolo Gradino Costa Retta DX  
33x120 Naturale (82)

**CHB A311** - Bianco  
**CHB A312** - Beige  
**CHB A313** - Grigio

Angolo Gradino Costa Retta DX  
33x120 Lappato (83)

**CHB A321** - Bianco  
**CHB A322** - Beige  
**CHB A323** - Grigio

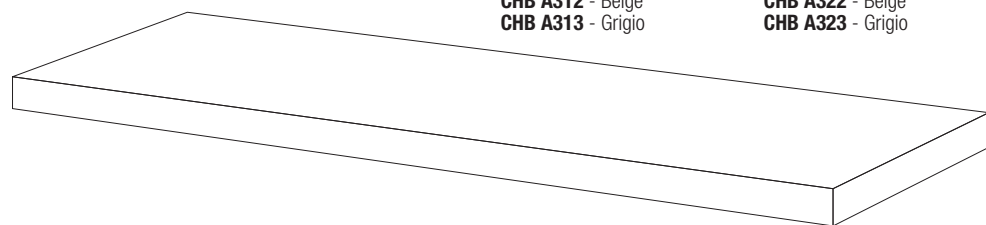

## I SUGGERIMENTI DEI NOSTRI ARCHITETTI

Our architects' suggestions.  
Les suggestions de nos architectes.  
Vorschläge unserer Architekten.

## Soluzioni per realizzare gradini coordinati alle superfici.

Examples of applications  
Exemples d'application  
Anwendungsbeispiele

La collezione è corredata di elementi per personalizzare i gradini degli ambienti interni.

Gli elementi sinistro e destro sono progettati per chiudere i lati aperti della scala. La larghezza di 120 cm dei pezzi solitamente consente di rivestire i gradini con un unico elemento monolitico (A). In presenza di larghezze inferiori di 120 cm è possibile tagliare in opera gli elementi per adattarli alla misura necessaria (B). Per rivestire gradini con larghezza superiore ai 120 cm è consigliato coprire lo spazio eccedente aggiungendo e tagliando all'occorrenza, il "gradino costa retta" centrale (C).

The collection features pieces to personalise indoor steps.

The right and left pieces are designed to close the open sides of the stairs. The width of the pieces is of 120 cm, which is usually sufficient to cover steps with one single piece (A). If the width of the step is less than 120 cm the pieces can be cut to measure during the installation (B). To cover steps that are wider than 120 cm, we recommend the use of the central "straight edge step" (C) to cover the extra space.

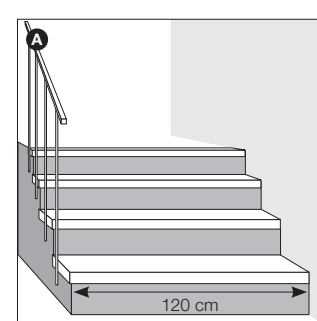

Angolo Gradino Costa Retta DL Sx  
33x120

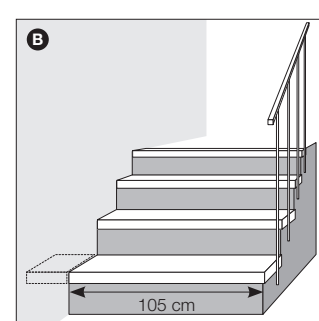

Angolo Gradino Costa Retta DL Dx  
33x120



Angolo Gradino Costa Retta DL Sx  
33x120

Gradino Costa Retta DL  
33x120

Angolo Gradino Costa Retta DL Dx  
33x120

La collection comprend des éléments pour personnaliser les marches des espaces internes.

Les éléments de gauche et de droite sont conçus pour fermer les côtés ouverts de l'escalier. La largeur de 120 cm des pièces permet généralement de revêtir les marches avec un seul élément monolithique (A). En présence de largeurs inférieures à 120 cm, on peut couper les éléments sur place afin de les adapter à la dimension nécessaire (B). Pour revêtir des marches d'une largeur supérieure à 120 cm, on conseille de couvrir l'espace en excès en ajoutant et en coupant au besoin la "marche à chant droit" centrale (C).

Die Kollektion verfügt über Elemente zur Personalisierung von Stufen in Innenräumen.

Die linken und rechten Elemente wurden so ausgelegt, dass sie die offenen Treppenseiten verschließen. Mit der Breite der Teile von 120 cm können die Stufen normalerweise mit einem einzigen monolithischen Element (A) verkleidet werden. Bei Breiten unter 120 cm können die Elemente bei der Verlegung auf das benötigte Maß (B) zugeschnitten werden. Bei Stufen mit einer Breite von über 120 cm wird empfohlen, die übermäßigen Flächen gegebenenfalls mit der mittleren Stufe, mit „gerade zugeschnittener Kante“ (C), zu abzudecken.

# Chambord outdoor

R11 A+B

GRES PORCELLANATO  
PORCELAIN . GRÈS CÉRAMÉ . FEINSTEINZEUG



## GRIGIO



**CHB E693** - 60,5x91 Naturale

**R1 A+B** 56

## BEIGE

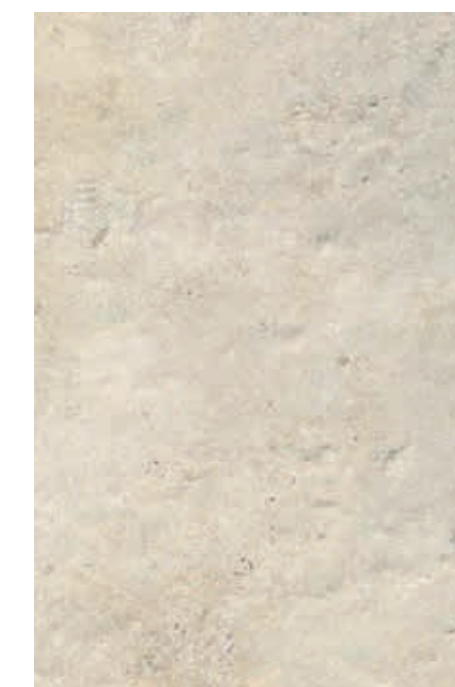

**CHB E692** - 60,5x91 Naturale

**R1 A+B** 56

Gradino Costa Retta  
33x91 Naturale (74)

**CHB G392** - Beige  
**CHB G393** - Grigio

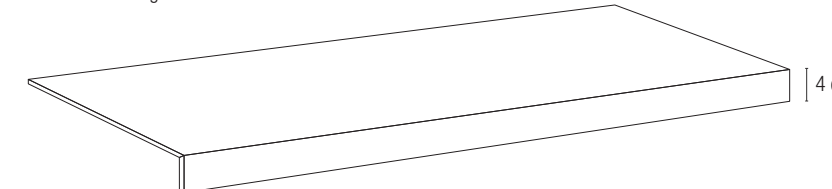

## DESTINAZIONI D'USO CONSIGLIATE DAI NOSTRI ARCHITETTI

Examples of applications suggested by our architects.  
Domaines d'utilisation conseillés par nos architectes.  
Von unseren Architekten empfohlene Anwendungsbereiche.

Ville, Appartamenti,  
Negozzi, Ristoranti, Bar,  
Alberghi, Centri benessere.

Villas, Apartments,  
Shops, Restaurants, Bars,  
Hotels and Wellness Centres.

Villas, Apartements,  
Magasins, Restaurants, Cafés,  
Hôtels, Centres de bien-être.

Häuser, Wohnungen,  
Geschäfte, Restaurants, Cafés,  
Hotels, Wellnesscenter.

Terrazze, Balconi, Verande,  
Passaggi in sicurezza, Zone relax,  
Spogliatoi.

Terraces, Balconies, Verandas,  
Safety passages, Relaxation areas,  
Changing rooms.

Terrasses, Balcons, Verandas,  
Passages sécurisés, Zones de détente,  
Vestiaires.

Terrassen, Balkons, Veranden,  
Sicherheitsdurchfahrten,  
Entspannungsbereiche, Umziehräume.



# Chambord gli inserti in legno

GRES PORCELLANATO  
PORCELAIN . GRÉS CÉRAMÉ . FEINSTEINZEUG



NATURALE E RETTIFICATO  
NATURAL AND RECTIFIED  
NATUREL ET RECTIFIÉ  
NATUR OBERFLÄCHE UND REKTIFIZIERT

15 x 120  
6" x 48"

## NATURE - TABACCO



NTU R113 - 15x120 Naturale

R9 63

## NATURE - CENERE



NTU R114 - 15x120 Naturale

R9 63

WOOD EFFECT INSERTS.  
COMBINAISONS EFFET BOIS.  
DIE EINSÄTZE AUS HOLZ.

ABBINAMENTO CONSIGLIATO.  
RECOMMENDED COMBINATION.  
ASSORTIMENT CONSEILLÉ.  
EMPFOHLENE KOMBINATION.



NTU R153 - 15x15  
Naturale  
R9 76



NTU R154 - 15x15  
Naturale  
R9 76

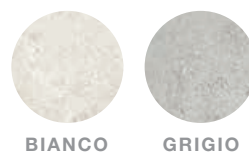

Bianco 60x60 . Tabacco Inserto in legno 15x15



Beige 60x90 . Tabacco Inserto in legno 15x15

Pavimento . Floor:  
Bianco 60x60  
Tabacco Inserto in legno 15x120, 15x15

Rivestimento . Wall tile:  
Sichenia: Collezione "Nature"  
Tabacco Decoro 3D 24,4x120





# Chambord

## DESTINAZIONI D'USO CONSIGLIATE DAI NOSTRI ARCHITETTI







Examples of applications suggested by our architects.  
 Domaines d'utilisation conseillés par nos architectes.  
 Von unseren Architekten empfohlene Anwendungsbereiche.

Ville, Appartamenti, Negozzi, Ristoranti, Bar, Alberghi, Centri benessere.	Villas, Apartments, Shops, Restaurants, Bars, Hotels and Wellness Centres.	Villas, Appartements, Magasins, Restaurants, Cafés, Hôtels, Centres de bien-être.	Häuser, Wohnungen, Geschäfte, Restaurants, Cafés, Hotels, Wellnesscenter.
--	--	---	---

Soggiorno, Cucina, Bagno, Sale da pranzo, Corridoi, Camere da letto, Sala ricevimento, Sale convegno, Zone relax, Spogliatoi.	Living Rooms, Kitchens, Bathrooms, Dining rooms, Corridors, Bedrooms, Reception rooms, Conference rooms, Relaxation areas and Changing rooms.	Salles de séjour, Cuisines, Salles de bains, Salles à manger, Couloirs, Chambres à coucher, Salles de réception, Salles des congrès, Zones de détente, Vestiaires.	Wohnzimmer, Küche, Badezimmer, Esszimmer, Korridore, Schlafzimmer, Empfangsräume, Tagungssäle, Entspannungsbereiche, Umziehräume.
--	--	---	--

## IMBALLI

Weights and pack . Poids et emballages . Gewicht und Verpackung

FORMATI Sizes . Formats . Formate	Pz x 	m² x 	kg x 	 x 	m² x 	kg x 
60x120	2	1,440	33,340	35	50,400	1167
60,5x91	3	1,652	39,329	32	52,840	1258
60x90 R	3	1,620	39,00	32	51,854	1248
30x90 R	4	1,080	26,00	48	51,84	1248
60,5x60,5	4	1,464	33,900	30	43,923	1017
60x60 R	4	1,440	33,340	30	43,200	1000
20x60	8	0,960	22,200	48	46,080	1066
60,5x91 Outdoor	3	1,652	39,329	32	52,854	1258
Battiscopa 7x60,5	12	0,508	11,170	48	24,390	536
Battiscopa 7x60	12	0,504	11,000	48	24,192	528
Gradino Costa Retta 33x91 Outdoor	2	0,601	16,204	-	-	-
Gradino Costa Retta 33x120	2	0,792	20,560	-	-	-
Angolo Gradino Costa Retta SX-DX 33x120	1	0,396	10,620	-	-	-



### CHAMBORD è un prodotto realizzato con la tecnologia digitale di Sichenia.

Sichenia Digital Technology è un avanzato procedimento di produzione che consente un incredibile realismo nella realizzazione di superfici in gres porcellanato; prova ne sono l'elevato numero di variazioni grafiche ottenibili e la sorprendente precisione nella riproduzione dei minimi particolari della materia naturale.

Sichenia sceglie ancora una volta l'avanguardia della tecnologia disponibile per conferire il massimo grado di ricercatezza al design ed alle prestazioni della proprie collezioni.

### CHAMBORD is a product manufactured using Sichenia's digital technology.

Sichenia Digital Technology is an advanced manufacturing process that enables incredible realism in the production of porcelain stoneware tiles; proof of this lies in the large number of graphic variations obtainable and the astonishing fidelity with which the smallest detail of the natural material is reproduced.

Sichenia has once again the chosen cutting-edge technology available to lend its collection the utmost sophistication in design and performance.

### CHAMBORD est un produit réalisé suivant la technologie numérique de Sichenia.

Sichenia Digital Technology est un processus avancé qui permet un réalisme incroyable en réalisant des surfaces en grès cérame ; le grand nombre de variations graphiques réalisables et la précision surprenante au niveau de la reproduction des moindres détails de la matière naturelle en sont la preuve.

Sichenia choisit une fois de plus l'avant-garde de la technologie disponible pour empreindre le design et les performances de ses collections du plus haut degré de raffinement.

### CHAMBORD ist ein mit der Sichenia-Digitaltechnologie geschaffenes Produkt.





Die Sichenia Digital Technology ist ein fortschrittliches Produktionsverfahren, das eine unglaubliche Wirklichkeitstreue bei der Herstellung von Oberflächen aus Feinsteinzeug ermöglicht. Beweis dafür sind die hohe Zahl von erzielbaren graphischen Varianten sowie die überraschende Genauigkeit bei der Nachbildung der kleinsten Details des Materials aus der Natur.

Sichenia entscheidet sich erneut für die fortschrittliche, verfügbare Technologie, um dem Design und den Leistungen ihrer Kollektionen eine besondere Auserlesenheit zu verleihen.



## CARATTERISTICHE TECNICHE DI SUPERFICIE

Technical surface properties . Caractéristiques techniques des surfaces . Technische Eigenschaften der Oberfläche

							
			CUOIO ASCIUTTO	GOMMA BAGNATA	R	A B C	
Naturale	<b>Resistenza alle macchie (Pulibilità)</b> Resistance to staining Résistance aux produits tachants Beständigkeit gegen <b>ISO 10545/14</b>	<b>Resistenza agli acidi e alle basi</b> Resistance to acids and bases Résistance aux acides et aux bases Beständigkeit gegen Säuren und Laugen <b>ISO 10545/13</b>	<b>Scivolosità</b> Slipperiness Glissance Rutschgefahr <b>B.C.R.A.</b>		<b>Scivolosità</b> Slipperiness Glissance Rutschgefahr <b>DIN 51130</b> <b>DIN 51097</b>		<b>Scivolosità</b> Slipperiness Glissance Rutschgefahr <b>DCOF</b> <b>Ansi A 137.1.2012</b>
60x120 60,5x91 30x90 60,5x60,5 20x60	5	U.A.	-	-	R 9	-	> 0,42 Wet
Lappato	5	U.A.	-	-	-	-	> 0,42 Wet
<b>60,5x91 outdoor</b>	5	U.A.	> 0,40	> 0,40	R 11	A + B	> 0,42 Wet

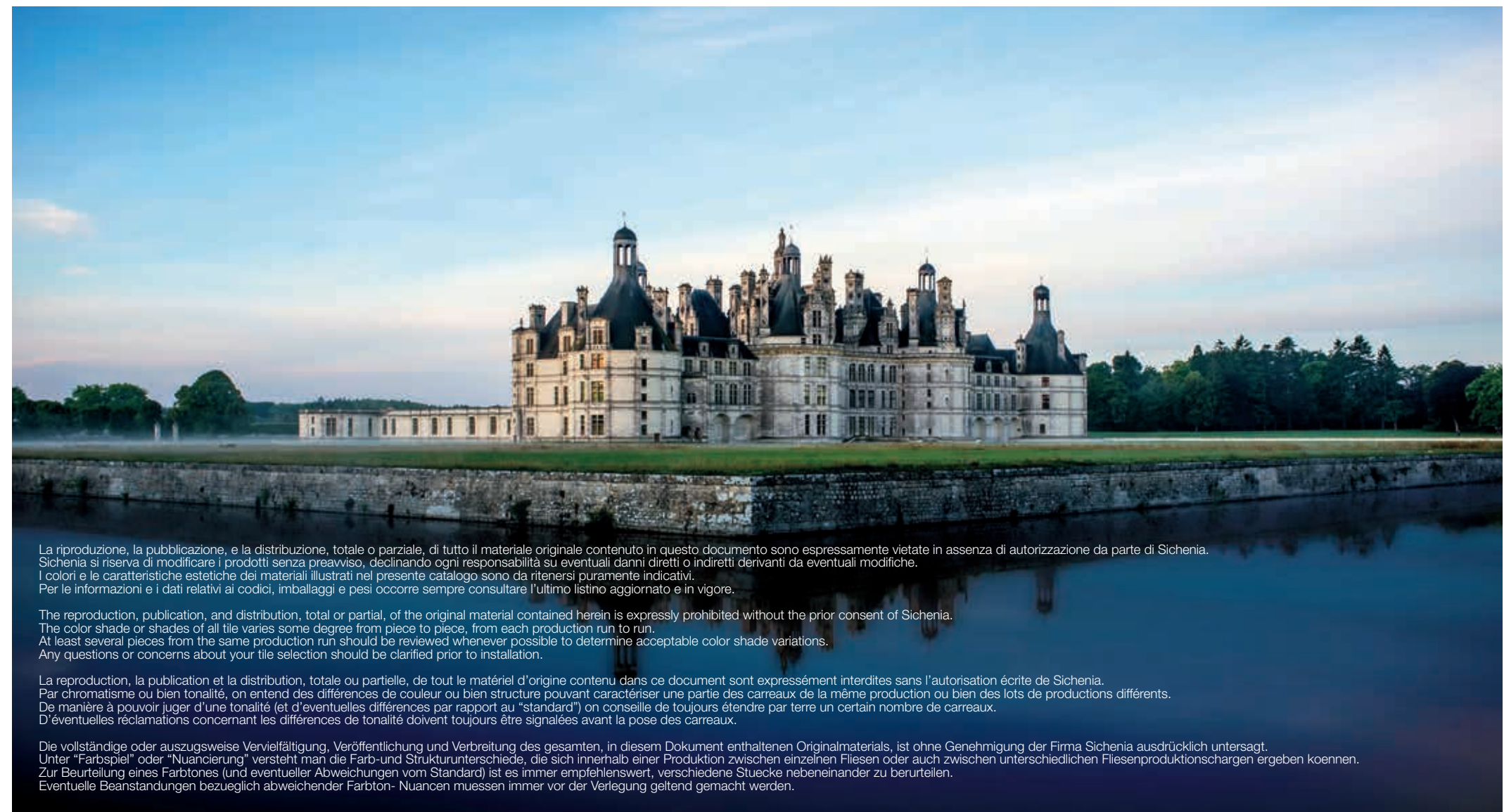

La riproduzione, la pubblicazione, e la distribuzione, totale o parziale, di tutto il materiale originale contenuto in questo documento sono espressamente vietate in assenza di autorizzazione da parte di Sichenia. Sichenia si riserva di modificare i prodotti senza preavviso, declinando ogni responsabilità su eventuali danni diretti o indiretti derivanti da eventuali modifiche. I colori e le caratteristiche estetiche dei materiali illustrati nel presente catalogo sono da ritenersi puramente indicativi. Per le informazioni e i dati relativi ai codici, imballaggi e pesi occorre sempre consultare l'ultimo listino aggiornato e in vigore.

The reproduction, publication, and distribution, total or partial, of the original material contained herein is expressly prohibited without the prior consent of Sichenia. The color shade or shades of all tile varies some degree from piece to piece, from each production run to run. At least several pieces from the same production run should be reviewed whenever possible to determine acceptable color shade variations. Any questions or concerns about your tile selection should be clarified prior to installation.

La riproduzione, la pubblicazione e la distribuzione, totale o parziale, de tout le matériel d'origine contenu dans ce document sont expressément interdites sans l'autorisation écrite de Sichenia. Par chromatisme ou bien tonalité, on entend des différences de couleur ou bien structure pouvant caractériser une partie des carreaux de la même production ou bien des lots de productions différents. De manière à pouvoir juger d'une tonalité (et d'éventuelles différences par rapport au "standard") on conseille de toujours étendre par terre un certain nombre de carreaux. D'éventuelles réclamations concernant les différences de tonalité doivent toujours être signalées avant la pose des carreaux.

Die vollständige oder auszugsweise Vervielfältigung, Veröffentlichung und Verbreitung des gesamten, in diesem Dokument enthaltenen Originalmaterials, ist ohne Genehmigung der Firma Sichenia ausdrücklich untersagt. Unter "Farbspiel" oder "Nuancierung" versteht man die Farb- und Strukturunterschiede, die sich innerhalb einer Produktion zwischen einzelnen Fliesen oder auch zwischen unterschiedlichen Fliesenproduktionschargen ergeben koennen. Zur Beurteilung eines Farbtönen (und eventueller Abweichungen vom Standard) ist es immer empfehlenswert, verschiedene Stücke nebeneinander zu beurteilen. Eventuelle Beanstandungen bezüglich abweichender Farbton- Nuancen muessen immer vor der Verlegung geltend gemacht werden.



*"Abitare Sichenia" è un brand italiano che produce pavimenti e rivestimenti in ceramica pensati per l'architettura contemporanea. Una gamma di prodotti di grande pregio estetico e resistenza, ottenuti con materie prime di alta qualità modellate dall'estro progettuale italiano.*

*"Abitare Sichenia" is an Italian brand that manufactures ceramic wall and floor coverings designed for contemporary architecture. It offers a range of products with high aesthetic quality and resistance, obtained with high quality raw materials shaped with Italian design flair.*



**Sichenia è da sempre concretamente impegnata nella tutela dell'ambiente.**

*Utilizza processi produttivi e tecnologie all'avanguardia che riducono notevolmente l'impatto ambientale delle attività in ogni fase esecutiva, dalla progettazione all'imballaggio finale del prodotto.*

**Sichenia has always been actively involved in safeguarding the environment.**

*It adopts avant-garde production processes and technologies that significantly reduce the environmental impact of each execution phase, from design to the final packaging of the product.*

# Chambord



Sichenia Gruppo Ceramiche S.p.A.

Via Toscana, 12 - 41049 Sassuolo (Modena, Italy)  
Tel. +39 0536.81.84.11 - Fax Italia +39 0536.81.01.05 / export +39 0536.80.08.15

[info@sichenia.it](mailto:info@sichenia.it) - [www.sichenia.it](http://www.sichenia.it)